

*Hygienic*

# Single Use CIP-Unit



▶ Application

- Supplying CIP liquid to process tanks and piping

▶ Advantages

- Single-use system
- Indirect heating system by double-tube-sheet heat exchanger enables clean CIP liquid to be supplied.
- Low price
- Space-saving design
- Free programming by using touch panel method.
- Set value free
- Simple operation
- Comprehensive monitoring screen showing operation conditions, temperatures, conductivity, etc.

▶ Basic specifications

		S-1 type	S-2 type	S-3 type	S-4 type	
Scope of application	Tank diameter	~1.2m	~2.5m	~4m	~5m	
	Spray ball	~1.2m	~2.5m	~4m	~5m	
	Rotary spray	—	—	~8m	~12m	
Piping diameter		~1.5s	~2s	~3s	~4s	
Control system		Sequencer control				
Power supply capacity (200V)		10kW	13kW	24kW	24kW	
Device specifications	Buffer tank	Capacity	300ℓ		500ℓ	
		Specification	Pressure: Atmosphere air open; Temperature: 95°C; Finish: Pickling			
		Accessories	Spray ball, Float-less level sensor, Sight glass			
	CIP supply pump	Capacity	100ℓ/min×40m	200ℓ/min×40m	400ℓ/min×40m	600ℓ/min×40m
		Material/finish	Material: SUS316, Internal: Pickling, External: G. B. S			
	Double-tube-sheet heat exchanger	Size	3s×1.5m	4s×1.5m	5s×1.5m	6s×1.5m
		Material/finish	Material: SUS316L, Internal/External Pickling			
	Dosing pump	Capacity	190~1900cc/min (60Hz)		310~3100cc/min (60Hz)	
			160~1600cc/min (50Hz)		260~2600cc/min (50Hz)	
	Dosing tank	Capacity/material	100ℓ PVC			
CIP (S) connection piping		1.5s	2s	2.5s	3s	
CIP (R) connection piping		2s	2.5s	3s	4s	
Dimensions	Width	2460mm	2600mm	2800mm	3050mm	
	Depth	1650mm		1850mm		
	Height	2200mm		2500mm		
Weight		650kg	700kg	800kg	900kg	
Utility	Fresh water	Connection	1.5s	2s	2.5s	3s
		Capacity	100ℓ/min×0.2MPaG	200ℓ/min×0.2MPaG	400ℓ/min×0.2MPaG	600ℓ/min×0.2MPaG
	Steam	Connection	JIS10K 40A FG	JIS10K 50A FG	JIS10K 80A FG	JIS10K 80A FG
		Capacity	270kg/hr×0.3MPaG	535kg/hr×0.3MPaG	1065kg/hr×0.3MPaG	1800kg/hr×0.3MPaG
	Instrumentation air	Connection/capacity	15A screw-in 3.3Nℓ/min×0.4MPaG			
Drainage	Capacity	6t/hr	12t/hr	24t/hr	36t/hr	
	Temperature	RT~95°C				

▶ Flow sheet

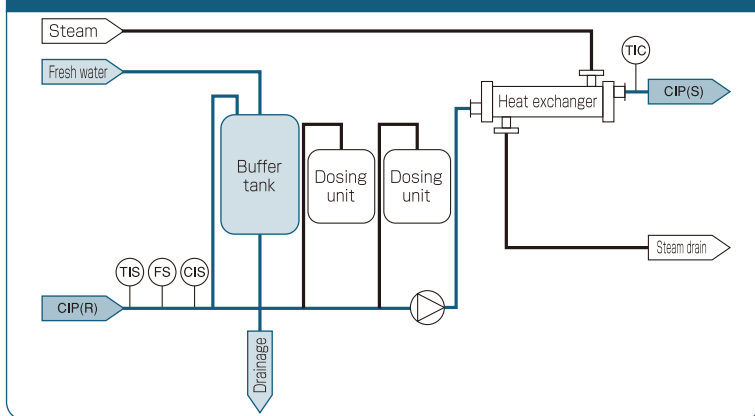

▶ Options

- Recorder
- Linkage with other equipment
- CIP flow meter
- Additional dosing unit
- Operation records
  - CF card
  - Printer

※ Note that specifications, performance, etc. are subject to change without notice due to product modification, etc.

TOSTE TOSTE Co.,Ltd.

Headquarters:  
1-32, Honden 2-chome, Nishi-ku, Osaka 550-0022  
TEL: +81-6-6585-0700 FAX: +81-6-6586-0708

Trade Department:  
TEL: +81-6-6585-2277 FAX: +81-6-6586-0708

TOSTE VIETNAM CO.,LTD  
Rental Factory 5-1, Road N3-2, Long Duc IP,  
Long Duc Ward, Long Thanh district,  
Dong Nai province, Vietnam  
TEL: +84-251-368-1800 FAX: +84-251-368-1881

肇慶東洋新島不銹鋼工程有限公司  
〒526072 肇慶市鼎湖区蓮花鎮7区蓮信路  
TEL: +86-758-2619887  
FAX: +86-758-261978